

CIERRE MECANICO DE CARTUCHO

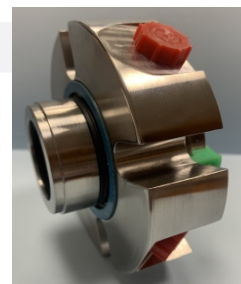

SERIE EC-

- ▶ CIERRE SENCILLO o DOBLE
- ▶ BI-EQUILIBRADO
- ▶ ESTACIONARIO

- ▶ MUELLES PROTEGIDOS
- ▶ AUTOALINEANTE
- ▶ INYECCIÓN Y QUENCH

Cierre mecánico de altas prestaciones.

Diseño de calidad para bombas (ANSI - DIN) y equipos con ejes rotativos, en todo tipo de aplicaciones industriales.

Cierres mecánicos simples y dobles de fácil instalación, sin mantenimiento preventivo.

Instalación rápida y sencilla, sin tener que hacer ningún tipo de modificaciones en los equipos.

Fabricación en métrica, pulgada y modificaciones bajo plano ó bajo muestra para adaptar el cierre a las necesidades de los equipos.

Aplicaciones:

- * Tratamiento de aguas
- * Industria alimentaria
- * Química y petroquímica
- * Industria Farmacéutica
- * Industria papelera
- * Industria general...

CERTIFICADOS
ATEX, FDA

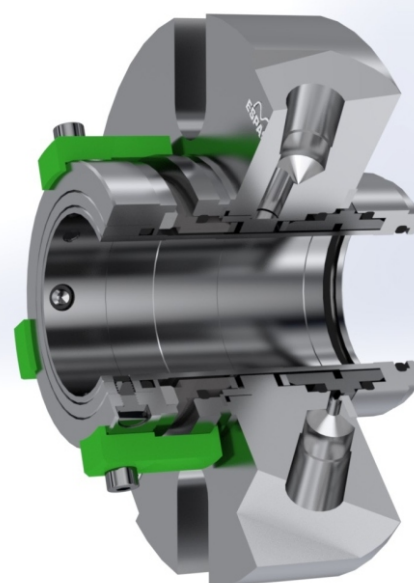

Límites de presión y temperatura

(Montaje en fábrica y prueba de presión)

Cierre sencillo: EC1 / EC3

- Presión de trabajo:	Vacío / 20 a 40bar
- Temperatura:	-40°C +300°C
- Velocidad de giro:	50 m/seg

Cierre mecánico Doble: ECD

- Presión de trabajo:	Vacío / 20 a 40bar
- Presión fluido barrera(*):	4 bar / 25 bar máx.
- Temperatura:	-40°C +300°C
- Velocidad de giro:	50 m/seg

(*) ESPASEME, S.A., recomienda que el fluido barrera esté a una temperatura inferior a 65 °C y con una lubricación superior o igual a la del agua. Viscosidad máx. 14 cst.

Características Constructivas

- Cierre Mecánico sencillo o doble
- Gama de medidas estandar: 2465 mm
- Independiente del sentido de giro
- Muelles múltiples protegidos
- Montaje interior
- Equilibrado, estacionario y autoalineante
- Juntas Tóricas

Combinación de Materiales

- Partes metálicas: A-316 /Hastelloy/Titanio/Duplex/...
- Muelles: Hastelloy C4
- Anillo giratorio: Silicio (Q1) / Tungsteno
- Anillo estacionario: Carbón / Silicio (Q1) / Tungsteno
- Cierres secundarios: EPDM / VITON*/ FFKM*/...

ECD

DOBLE

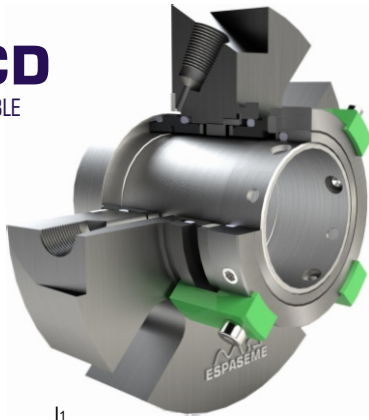

ECDB

DOBLE CON
CANALES DE
BOMBEO EN
EL CARTUCHO



Tabla de dimensiones - Medidas en mm *(sujetas a cambios.)

d ₁ h ₆	d ₃	Ø CAJERA MIN	D	G	S	l ₁	l ₂	l ₃	l ₄
24	38.0	40.0	105.0	54	13	70.5	51.3	19.2	28
25	39.5	41.0	105.0	54	13	70.5	51.3	19.2	28
28	42.5	44.0	108.0	58	13	70.5	51.3	19.2	28
30	44.0	46.0	109.5	61	13	70.5	51.3	19.2	28
32	46.0	48.0	109.5	61	13	70.5	51.3	19.2	28
33	47.0	49.0	109.5	61	13	70.5	51.3	19.2	28
35	49.0	51.0	109.5	64	13	70.5	51.3	19.2	28
38	55.5	57.2	124.0	71	17	76.2	55.5	20.7	28
40	56.5	58.0	127.0	71	17	76.2	55.5	20.7	28
42	58.5	60.0	127.0	71	17	76.2	55.5	20.7	28
43	59.5	61.0	127.0	71	17	76.2	55.5	20.7	28
45	61.5	63.5	138.0	81	17	76.2	55.5	20.7	28
48	64.5	66.7	138.0	81	17	76.2	55.5	20.7	28
50	66.5	68.0	138.0	81	17	76.2	55.5	20.7	28
53	69.0	71.0	152.0	90	17	76.2	55.5	20.7	28
55	72.0	74.0	152.0	90	17	76.2	55.5	20.7	28
58	74.0	76.2	165.0	97	17	76.2	55.5	20.7	28
60	77.0	79.5	165.0	97	17	76.2	55.5	20.7	28
63	83.0	86.0	178.0	109	19	83.5	58.5	25.0	29
65	86.0	89.0	178.0	109	19	83.5	58.5	25.0	29

Tabla de dimensiones - Medidas PULGADA en mm *(sujetas a cambios)

d ₁ h ₆	d ₃	Ø CAJERA MIN	D	G	S	l ₁	l ₂	l ₃	l ₄
25.4	39.5	41.0	105.0	54	13	70.5	51.3	19.2	28
28.6	42.5	44.0	108.0	58	13	70.5	51.3	19.2	28
31.7	46.0	48.0	109.5	61	13	70.5	51.3	19.2	28
34.9	49.0	51.0	109.5	64	13	70.5	51.3	19.2	28
38.1	55.5	57.2	124.0	71	17	76.2	55.5	20.7	28
41.2	58.5	60.0	127.0	71	17	76.2	55.5	20.7	28
44.4	61.5	63.5	138.0	81	17	76.2	55.5	20.7	28
47.6	64.5	66.7	138.0	81	17	76.2	55.5	20.7	28
50.8	66.5	68.0	138.0	81	17	76.2	55.5	20.7	28
53.9	72.0	74.0	152.0	90	17	76.2	55.5	20.7	28
57.1	74.0	76.2	165.0	97	17	76.2	55.5	20.7	28
60.3	77.0	79.5	165.0	97	17	76.2	55.5	20.7	28
63.5	83.0	86.0	178.0	109	19	83.5	58.5	25.0	29

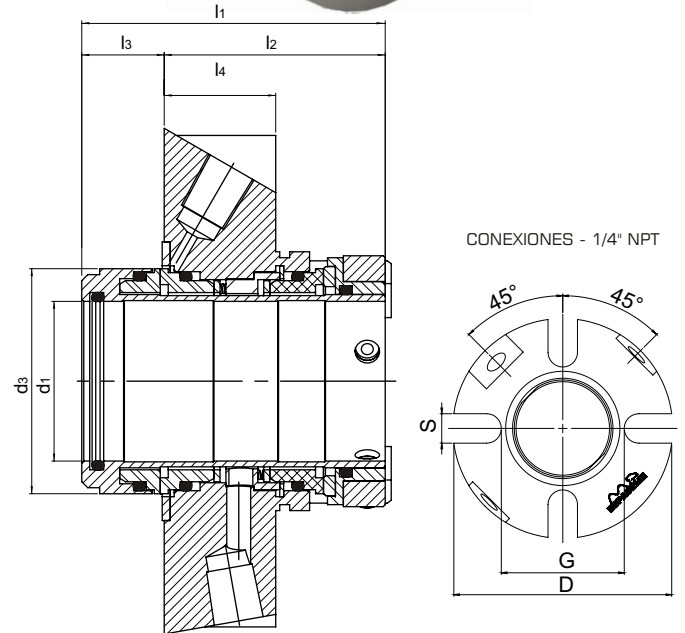
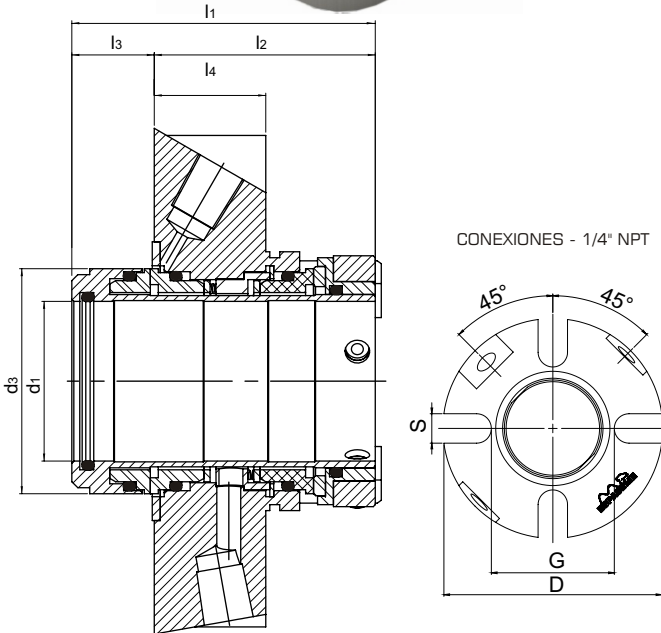
Tabla de dimensiones - Medidas en mm *(sujetas a cambios.)

d ₁ h ₆	d ₃	Ø CAJERA MIN	D	G	S	l ₁	l ₂	l ₃	l ₄
24	38.0	40.0	105.0	54	13	70.5	51.3	19.2	28
25	39.5	41.0	105.0	54	13	70.5	51.3	19.2	28
28	42.5	44.0	108.0	58	13	70.5	51.3	19.2	28
30	44.0	46.0	109.5	61	13	70.5	51.3	19.2	28
32	46.0	48.0	109.5	61	13	70.5	51.3	19.2	28
33	47.0	49.0	109.5	61	13	70.5	51.3	19.2	28
35	49.0	51.0	109.5	64	13	70.5	51.3	19.2	28
38	55.5	57.2	124.0	71	17	76.2	55.5	20.7	28
40	56.5	58.0	127.0	71	17	76.2	55.5	20.7	28
42	58.5	60.0	127.0	71	17	76.2	55.5	20.7	28
43	59.5	61.0	127.0	71	17	76.2	55.5	20.7	28
45	61.5	63.5	138.0	81	17	76.2	55.5	20.7	28
48	64.5	66.7	138.0	81	17	76.2	55.5	20.7	28
50	66.5	68.0	138.0	81	17	76.2	55.5	20.7	28
53	69.0	71.0	152.0	90	17	76.2	55.5	20.7	28
55	72.0	74.0	152.0	90	17	76.2	55.5	20.7	28
58	74.0	76.2	165.0	97	17	76.2	55.5	20.7	28
60	77.0	79.5	165.0	97	17	76.2	55.5	20.7	28
63	83.0	86.0	178.0	109	19	83.5	58.5	25.0	29
65	86.0	89.0	178.0	109	19	83.5	58.5	25.0	29

Tabla de dimensiones - Medidas PULGADA en mm *(sujetas a cambios)

d ₁ h ₆	d ₃	Ø CAJERA MIN	D	G	S	l ₁	l ₂	l ₃	l ₄
25.4	39.5	41.0	105.0	54	13	70.5	51.3	19.2	28
28.6	42.5	44.0	108.0	58	13	70.5	51.3	19.2	28
31.7	46.0	48.0	109.5	61	13	70.5	51.3	19.2	28
34.9	49.0	51.0	109.5	64	13	70.5	51.3	19.2	28
38.1	55.5	57.2	124.0	71	17	76.2	55.5	20.7	28
41.2	58.5	60.0	127.0	71	17	76.2	55.5	20.7	28
44.4	61.5	63.5	138.0	81	17	76.2	55.5	20.7	28
47.6	64.5	66.7	138.0	81	17	76.2	55.5	20.7	28
50.8	66.5	68.0	138.0	81	17	76.2	55.5	20.7	28
53.9	72.0	74.0	152.0	90	17	76.2	55.5	20.7	28
57.1	74.0	76.2	165.0	97	17	76.2	55.5	20.7	28
60.3	77.0	79.5	165.0	97	17	76.2	55.5	20.7	28
63.5	83.0	86.0	178.0	109	19	83.5	58.5	25.0	29